

ALBERO DI CORREDO CON E SENZA INTARDER QUILL SHAFT WITH OR WITHOUT INTARDER HEAVY DUTY "ZF TRAXON"

CODICE
CODE

09301080113

ZF

Il fissaggio al cambio con più fori consente di distribuire su più punti il momento peso di PTO e pompa. La flangia è costruita per prelevare olio in pressione dal foro appositamente presente sul cambio ed utilizzarlo per la lubrificazione interna o esterna della PTO.

The fitment to the gearbox based on holes spreads the mass moment of PTO/pump assembly equally over more points. The flange is designed to take out pressurized oil from the gearbox through the dedicated port available on the transmission and to get use of it either for internal or external PTO lubrication.

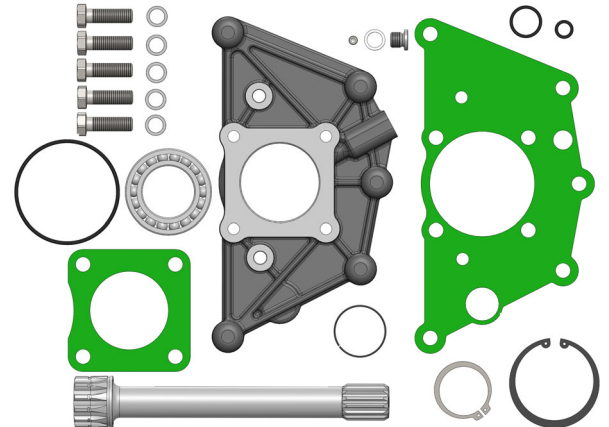

99740009310

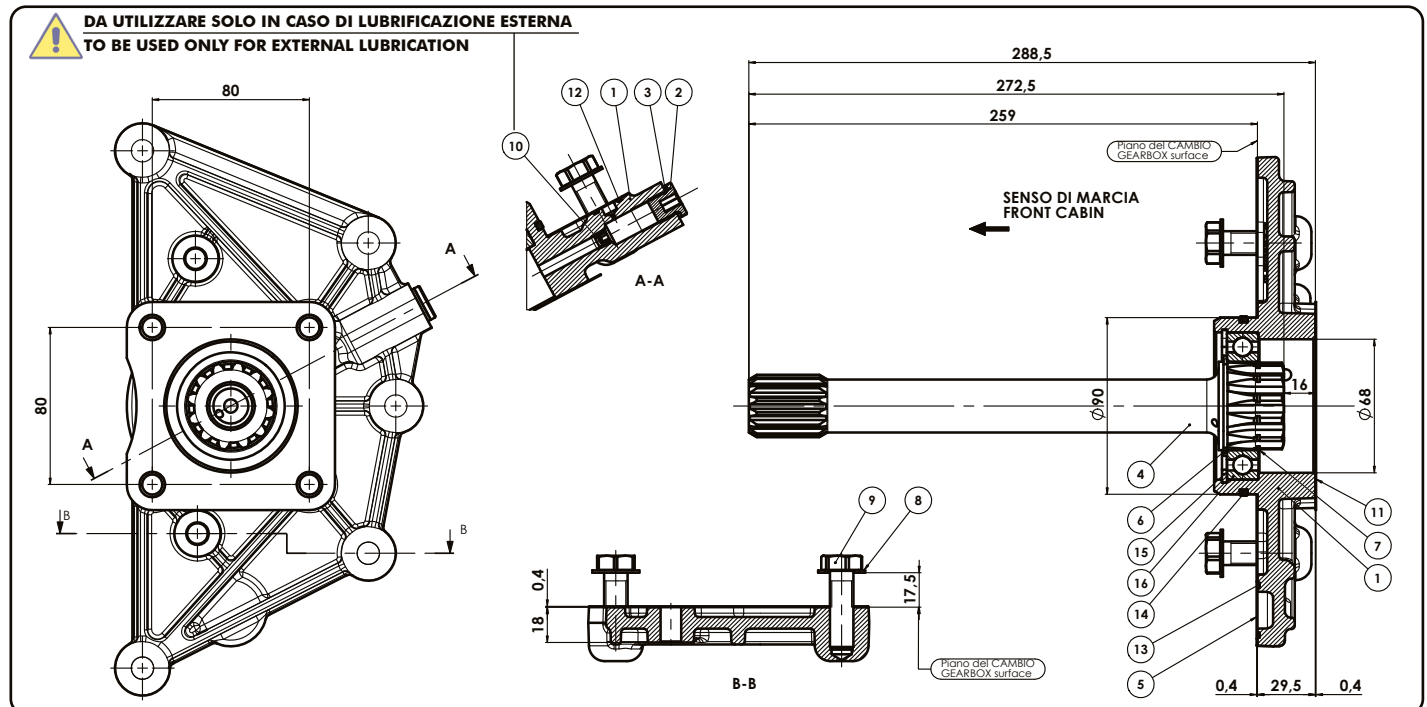

N°	Codice / Code	Descrizione / Description	Q.
1	51500701715	FLANGIA PTO-CAMBIO ZF "TRAXON" / FLANGE	1
2	11500600117	TAPPO CIECO ACCIAIO TCE 1/4" DIN 908 / PLUG	1
3	11600900158	RONDELLA ALLUMINIO 13,5X18X1,5 (1/4") / WASHER	1
4	52100000890	ALBERO CORREDO Z14 L272-ZF16AS2200+INT / QUILL SHAFT	1
5	50700101272	GUARNIZIONE PTO-CMB ZF TRAXON / GASKET	1
6	50100200425	ANELLO SEEGER 45 E UNI 7435 / SEEGER	1
7	51200000068	ANELLO FERMA CUSCINETTO / RING	1
8	50100750126	RONDELLA NORD-LOCK x M12 DELTA PROTEKT / NORD-LOCK WASHER	5
9	50200500073	VITE TE M12x40 UNI EN 24017 / SCREW	5
10	50401000018	TAPPO CONICO 1/16-27 PTF LEVEL SEAL / CONICAL PLUG	1
11	50700100077	GUARNIZIONE FINESTRA ISO 7707 Ø68 / GASKET	1
12	50600602050	GUARNIZIONE O-R 2050 (1.78 x 12.42) FKM/FPM / GASKET	1
13	50600602100	GUARNIZIONE O-R 2100 (1.78 x 25.12) FKM/FPM / GASKET	1
14	50600684030	GUARNIZIONE O-R-M 0840-30 (3 x 84) FKM/FPM / GASKET	1
15	50100100695	ANL. SEG. NRM. 75 I / SEEGER	1
16	51000145755	CUSCINETTO A SFERE 45x75x16 EUR. 6009 / BALL BEARING	1

12/02/2023

99709310113 Rev. AC

pag.141

O.M.F.B. S.p.A. Hydraulic Components

We reserve the right to make any changes without notice.

Edition 2007.12 No reproduction, however partial, is permitted.

Via Cave, 7/9 25050 Provaglio d'Iseo (Brescia) Italy Tel.: +39.030.9830611
Fax: +39.030.9839207-208 Internet:www.omfb.it e-mail:contatti@omfb.it

COMPANY WITH
QUALITY SYSTEM
CERTIFIED BY DNV GL
= ISO 9001:2015 =

OMFB

HYDRAULIC COMPONENTS

La flangia fornita è predisposta **DI SERIE** per una **LUBRIFICAZIONE INTERNA** delle PTO montate.
The flange is prepared for **INTERNAL LUBRICATION** to the PTO fitted together **AS A STANDARD**.

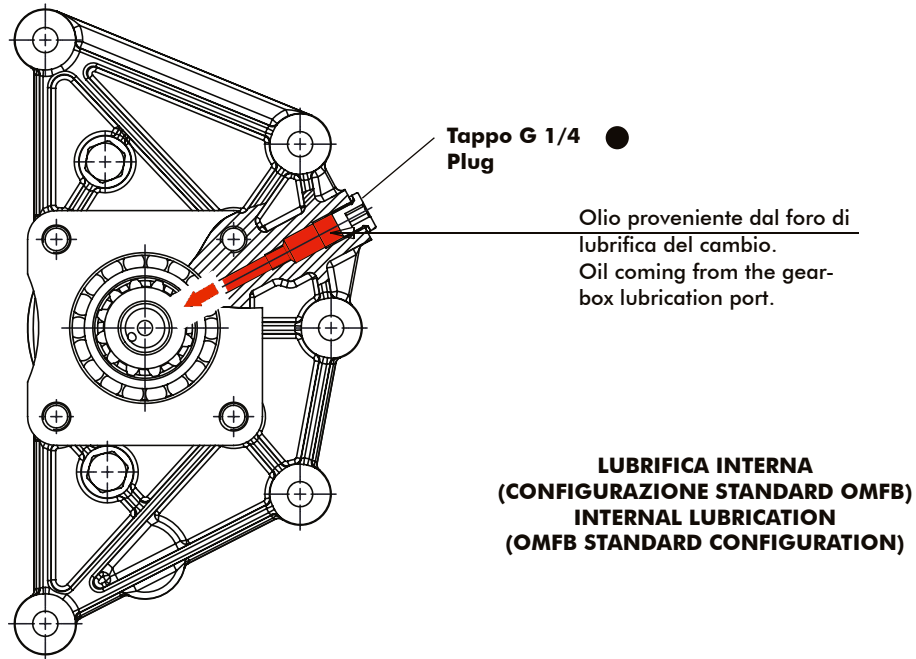

Prima di iniziare il montaggio, è necessario porre attenzione a quanto indicato di seguito:
in caso di montaggio di PTO doppia uscita, singola uscita in posizione orizzontale o singola uscita in posizione verticale con l'uscita verso l'alto, è **NECESSARIO** lubrificare le PTO stesse mediante kit di lubrifica appositamente predisposti. Per questo è **INDISPENSABILE** rimuovere ed eliminare il tappo G 1/4 ● e chiudere, mediante il grano conico fornito ■, il passaggio di olio all'interno delle PTO, in modo da costringerne il flusso nel tubo esterno. L'eventuale kit di lubrifica si individua e si monta come indicato in **Tabella 1a e 1b**.

Before starting the mounting operation it is necessary to follow carefully this procedure:
in case of mounting of double output PTO's, single output PTO's in horizontal or vertical UP position it is necessary to lubricate those PTO's by using the specific lubrication kits. To do so it is **STRICTLY** necessary remove and dispose the G1/4 plug ● ; close the PTO internal oil flow by using the tapered grub screw ■ supplied in the kit in such a way to force the oil flow to the external pipe. The proper lubrication kit can be identified and fitted as shown in the **Table 1a and 1b**.

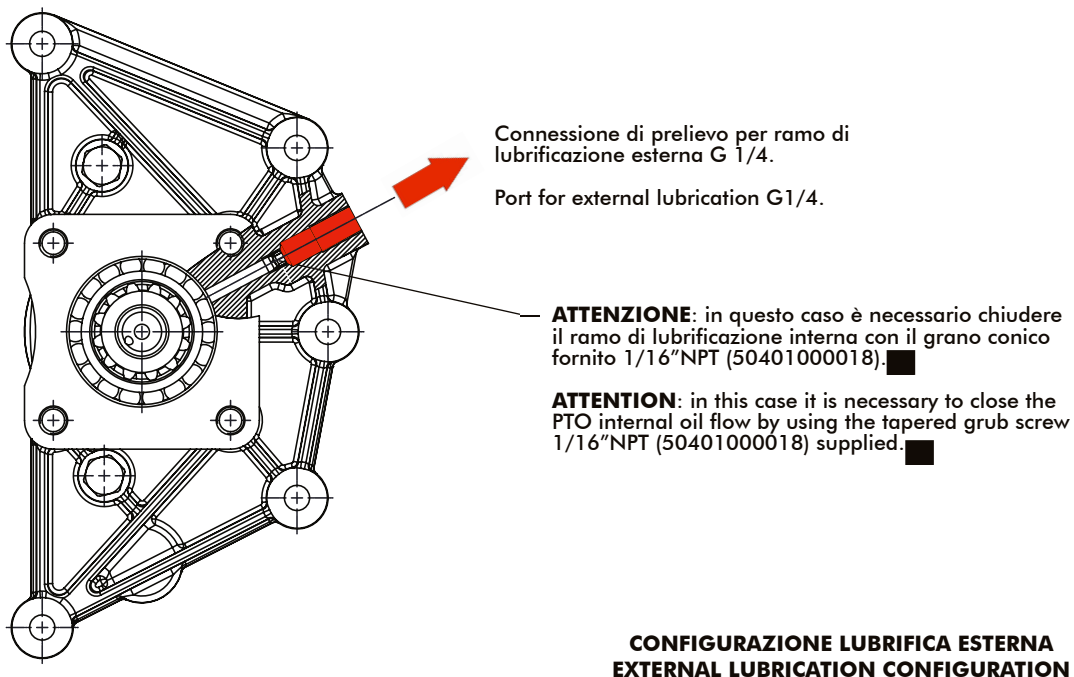























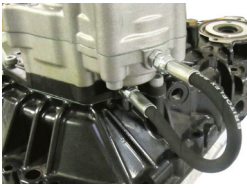

PTO	MONTAGGIO PTO PTO MOUNTING	KIT LUBIFICA LUBRICATION KIT	IMMAGINE MONTAGGIO MOUNTING PICTURES
POWERFUL e 01000700172	<p>Montaggio verticale uscita in basso</p> <p>Vertical mounting low output</p> 	<p>NON NECESSARIO</p> <p>NOT NECESSARY</p>	
	<p>Montaggio orizzontale uscita laterale</p> <p>Horizontal mounting side output</p> 	 <p>09400100181 DIRITTO-DIRITTO STRAIGHT-STRAIGHT</p>	
	<p>Montaggio verticale uscita in alto</p> <p>Vertical mounting up output</p> 	 <p>09400100118 DIRITTO-CON OCCHIELLO STRAIGHT-WITH EYE</p>	
010071 010072 010073	<p>Montaggio verticale uscita in basso</p> <p>Vertical mounting low output</p> 	<p>NON NECESSARIO</p> <p>NOT NECESSARY</p>	
	<p>Montaggio orizzontale uscita laterale</p> <p>Horizontal mounting side output</p> 	 <p>09400100118 DIRITTO-CON OCCHIELLO STRAIGHT-WITH EYE</p>	
	<p>Montaggio verticale uscita in alto</p> <p>Vertical mounting up output</p> 	 <p>09400100181 DIRITTO-DIRITTO STRAIGHT-STRAIGHT</p>	
<p>PTO DOPPIA USCITA Ø68</p> <p>DOUBLE OUTPUT PTO Ø68</p> <p>01003612173 01003912170</p> 	 <p>09400100118 DIRITTO-CON OCCHIELLO STRAIGHT-WITH EYE</p>		

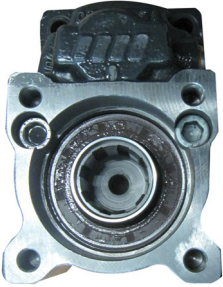
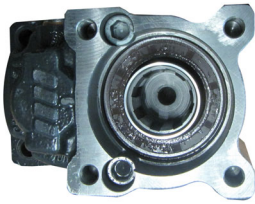
Tabella / Table 1a

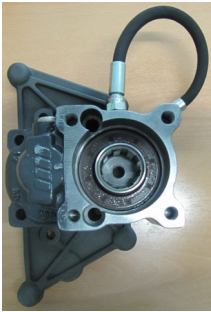
PTO	MONTAGGIO PTO PTO MOUNTING	KIT LUBIFICA LUBRICATION KIT	IMMAGINE MONTAGGIO MOUNTING PICTURES
	<p>Montaggio verticale uscita in basso</p> <p>Vertical mounting low output</p> 	<p>NON NECESSARIO</p> <p>NOT NECESSARY</p>	
<p>010061 010062 010063</p>	<p>Montaggio orizzontale uscita laterale</p> <p>Horizontal mounting side output</p> 	 <p>09400100181 DIRITTO-DIRITTO STRAIGHT-STRAIGHT</p>	
	<p>Montaggio verticale uscita in alto</p> <p>Vertical mounting up output</p> 	 <p>09400100190 CON OCCHIELLO-CON OCCHIELLO WITH EYE-WITH EYE</p>	
<p>010030 010031 012030 012031 010100 010101</p>		 <p>09400100118 DIRITTO-CON OCCHIELLO STRAIGHT-WITH EYE</p>	

99740009310

12/02/2023

Tabella / Table 1b

99709310113 Rev: AC

PREPARAZIONE E MONTAGGIO PTO / PTO MOUNTING & PREPARATION

- 1) Smontare il coperchio posteriore originale (fig.1). Rimuovere la guarnizione metallica originale ed il relativo tappo di fermo (fig.2). Rimuovere eventuali tracce di pasta/prodotto sigillante e vernice dalla zona indicata (fig.3).
1) Remove the original rear cover (fig.1). Remove the original metallic gasket and related plug (fig.2). Remove any potential residual of sealant and/or paint from the highlighted area (fig.3).



fig.1

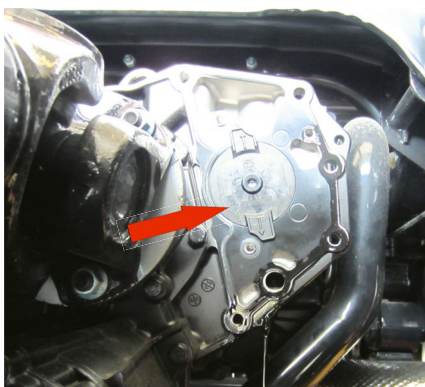

fig.2

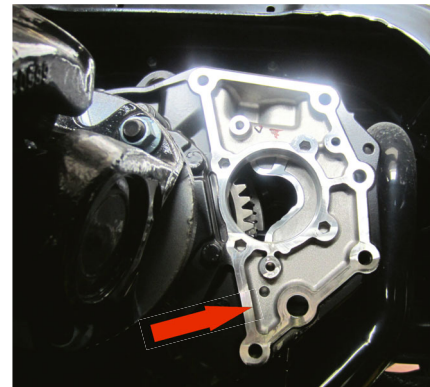
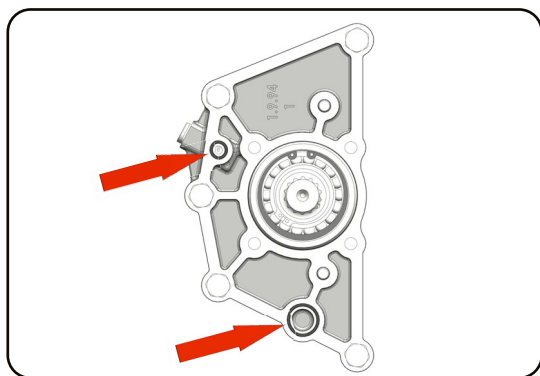

fig.3



- 2) Utilizzando grasso montare nella flangia le guarnizioni OR indicate.
2) By applying some grease fit the O-ring seals shown into the plate.



In questa fase, **SE NECESSARIA LUBRIFICA ESTERNA**, rimuovere il tappo G 1/4 e montare il grano filettato 1/16" NPT.
IF EXTERNAL LUBRICATION IS REQUIRED, please remove the G1/4 plug and fit the tapered grub screw 1/16" NPT.

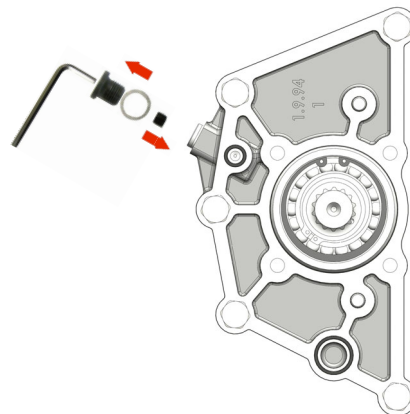

- 3) Posizionare la guarnizione fornita nel kit.
3) Place the gasket supplied in the kit.

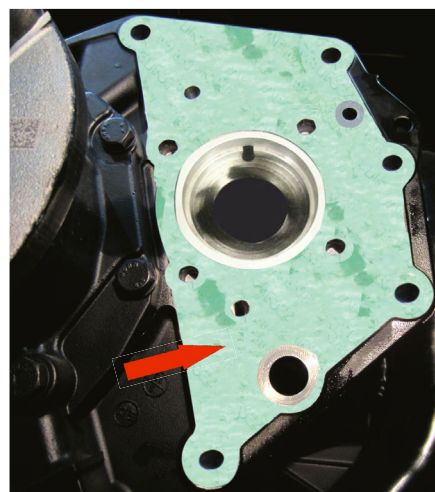

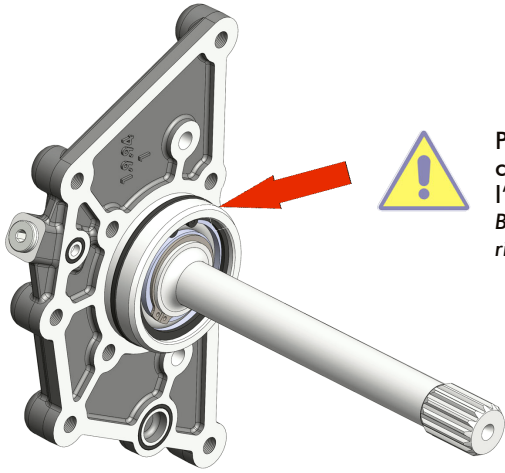

Prima di procedere al montaggio del gruppo, lubrificare con un filo di olio il centraggio e la guarnizione OR. Successivamente, porre attenzione durante l'inserimento a non danneggiare la suddetta guarnizione.
Before proceeding with the mounting of the assembly, lube the centering ring and O-ring seal. Pay attention not to damage this seal while fitting it.

- 5) Montare la flangia con l'albero di corredo completo nel cambio rispettando le coppie di serraggio.
Fit the flange with the complete quill shaft in the gearbox watching the tightening torque.



Riutilizzare le 2 viti M10 originali ZF, tolte in precedenza, nelle posizioni indicate. (sul retro utilizzare invece le viti M12x40 fornite nel kit)
Re-use in the given positions the Nos.2 original ZF M10 screws previously removed (on the rear use the M12x40 screws supplied in the kit).

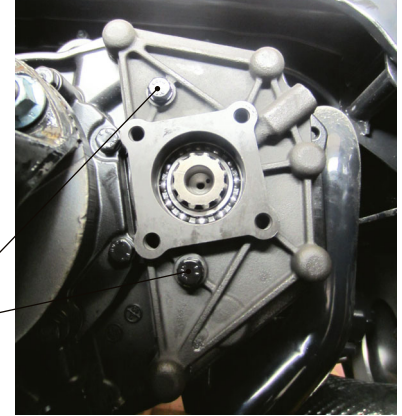

- 6) Se necessario montare il tubo di lubrifica (vedere Tabella 1).
If necessary fit the lubrication hose (see table 1).

- 7) Montare la guarnizione indicata in figura.
Fit the gasket as shown in picture.

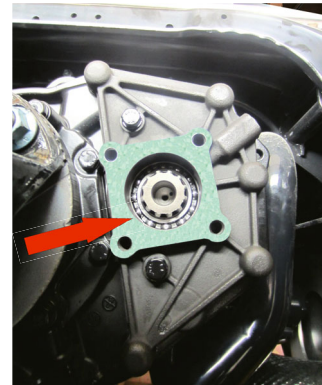

- 8) Montare la PTO.
Mount the PTO.

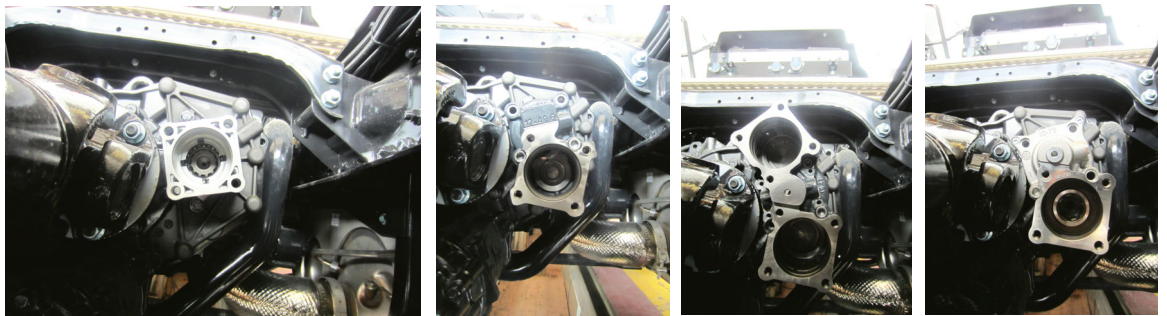

Data la fuoriuscita di una discreta quantità di olio durante le fasi di montaggio, è assolutamente necessario controllare il livello di olio e rabboccare.
Since oil may leak out from gearbox when assembling the PTO, it is strictly necessary to check oil level and top up.



COPPIA DI SERRAGGIO

Diametro filetto - Vite (mm)	M8	M10	M12	UNC 3/8	UNC 7/16
Coppia chius. viti e dadi (Nm)	25	50	80	25	60
Coppia di chius. prigionieri (Nm)	10	20	30	10	20



Per i cambi in alluminio la coppia di serraggio deve essere diminuita del 30%.

Nota per la coppia di serraggio: le coppie di serraggio indicate sono puramente indicative e non sostituiscono le indicazioni date dal costruttore del veicolo o dal costruttore del cambio.

TIGHTENING TORQUE

Thread diameter - Screw (mm)	M8	M10	M12	UNC 3/8	UNC 7/16
Screws and nuts torque (Nm)	25	50	80	25	60
Studs torque (Nm)	10	20	30	10	20



For aluminium gearboxes the tightening torque needs to be reduced by 30%.

Note on the tightening torque: the tightening torques reported are only meant as a guide and do not replace the indications given by the vehicle's manufacturer of the gearbox manufacturer.

Per ulteriori informazioni sul montaggio della PTO, consultare l'istruzione allegata alla PTO.
In order to get more information concerning PTO installation please check the Instructions sheet delivered with the PTO.

99740009310

12/02/2023

99709310113 Rev. AC